

Customer:		Ref.:	
Item	Quantity	Required flow	n.d.
Type	CENTRIFUGAL PUMP WITH HORIZONTAL SHAFT	Model	MEC-MG125HT/2A

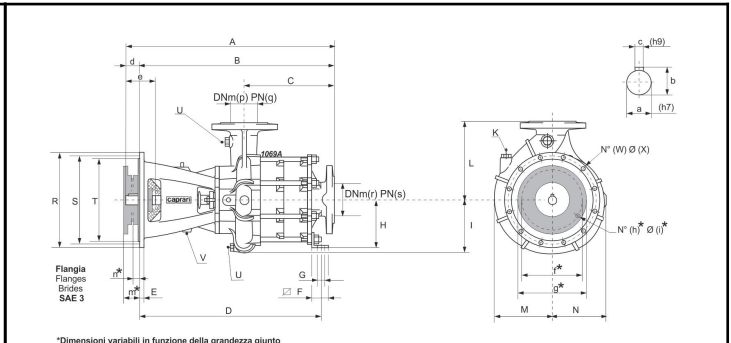
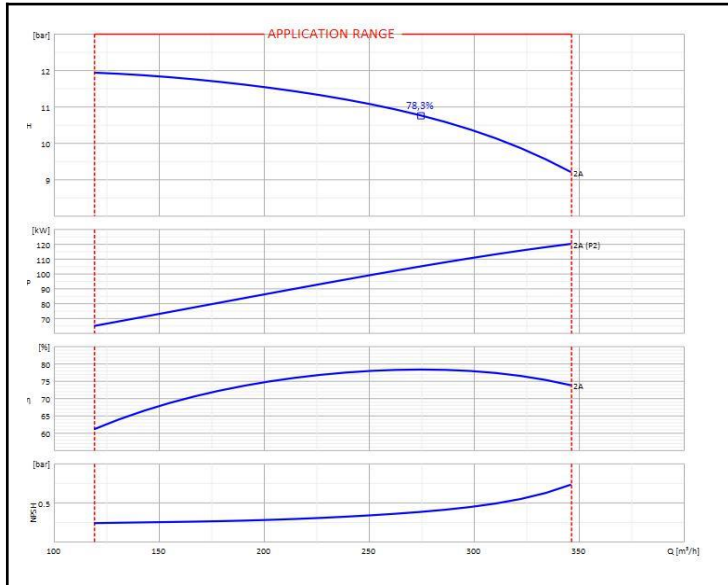

*Dimensioni variabili in funzione della grandezza giunto
*Variable dimensions according to coupling's size

Dimensions [mm]							
A	786	K	G 3/8"	W	12	r	150
B	766	L	425	X	11,5	s	16
C	295	M	303	a	50		
D	718	N	270	b	52,5		
E	20	R	451	c	14		
F	70	S	428,6	d	20,2		
G	32	T	409,6	e	87,5		
H	280	U	G 3/8"	p	125		
I	294	V	G 1/2"	q	16		

OPERATING DATA- ISO 9906:2012 3B -					CONSTRUCTION CHARACTERISTICS			
Q [m³/h]	H [bar]	P [kW]	η [%]	NPSH [bar]	UNI delivery flange DN	100	PN	16
					UNI suction flange DN	125	PN	16
					Total weight	264		Kg
					No. Stages		2	
					Pump seal		Packing	
					Type of installation		Horizontal	

OPERATING LIMITS			OPERATING CHARACTERISTICS			
Pumped liquid	Water		Service flow rate		n.d.	n.d.
Max. temperature of pumped liquid	n.d.		Service head		n.d.	n.d.
Maximum density	1	kg/dm³	Qmin	Qmax	119,12	346,32
Maximum viscosity	1	mm²/s	H (Q=0)	Hmax (Qmin)	12,14	11,93
Max. solid content	20	g/m³	P2 Duty Point	P2max	n.d.	120
Max. no. starts/hr	n.d.		Pump hydraulic efficiency		n.d.	n.d.
Maximum operating time with closed port	10min (2400rpm) [40 °C]		Rotation speed		1600	1/min
			Sense of rotation (*)		n.d.	
			Number of pumps installed		Operating	Stand-by
					1	0

PUMP MATERIALS	
Delivery casing	Cast iron
Suction casing	Cast iron
Impeller	Cast iron
Diffuser	Cast iron
Casing	Cast iron
Stuffing box	Cast iron
Wear ring	Cast iron
Shaft bearing bush	Stainless steel/rubber
Spacer sleeve	Steel
Packing	Graphited cord
Lantern bracket	Cast iron
Pump shaft	Stainless steel
Bearing flange	Cast iron
Shaft sleeve	Stainless steel
Shaft guard	Stainless steel
Tie rod	Steel

Notes:	(*) View from motor coupling side
OFFER No.	Pos.
	Date 17/05/2019