

UNIT FOR CONTROL AND PROTECTION OF IRRIGATION MOTOR PUMPSET TYPE CEM-370

INSTRUCTION AND USER MANUAL



Complete with display for displaying the following functions:

- pump protection exclusion
- battery and oil lights
- protections intervention
- hour-meter
- timer
- fuel level indicator
- tachometer
- battery voltmeter

PROTECT THE MOTOR PUMP SETS BY STOPPING THEM IN THE EVENT OF

- low oil pressure
- over-temperature
- belt breakage
- minimum fuel level
- available A1
- A2 (low diesel fuel pressure)
- low coolant level
- insufficient pump water pressure

Assembly also on the machine and in the open air.

DIMENSIONS

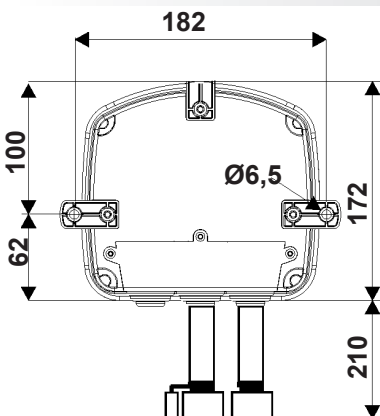

Fixing system

With two or three clamps

On request with vibration dampers fitted on the top part of the control unit

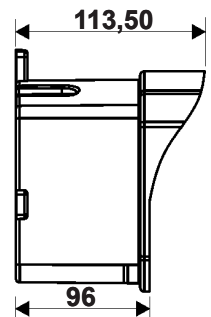
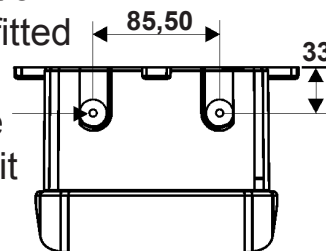

PARMA



ELCOS®

ITALY

Tel. +39 0521/772021 Fax +39 0521/270218
E-mail: info@elcos.it - HTTP://www.elcos.it

BRIEF INSTRUCTIONS

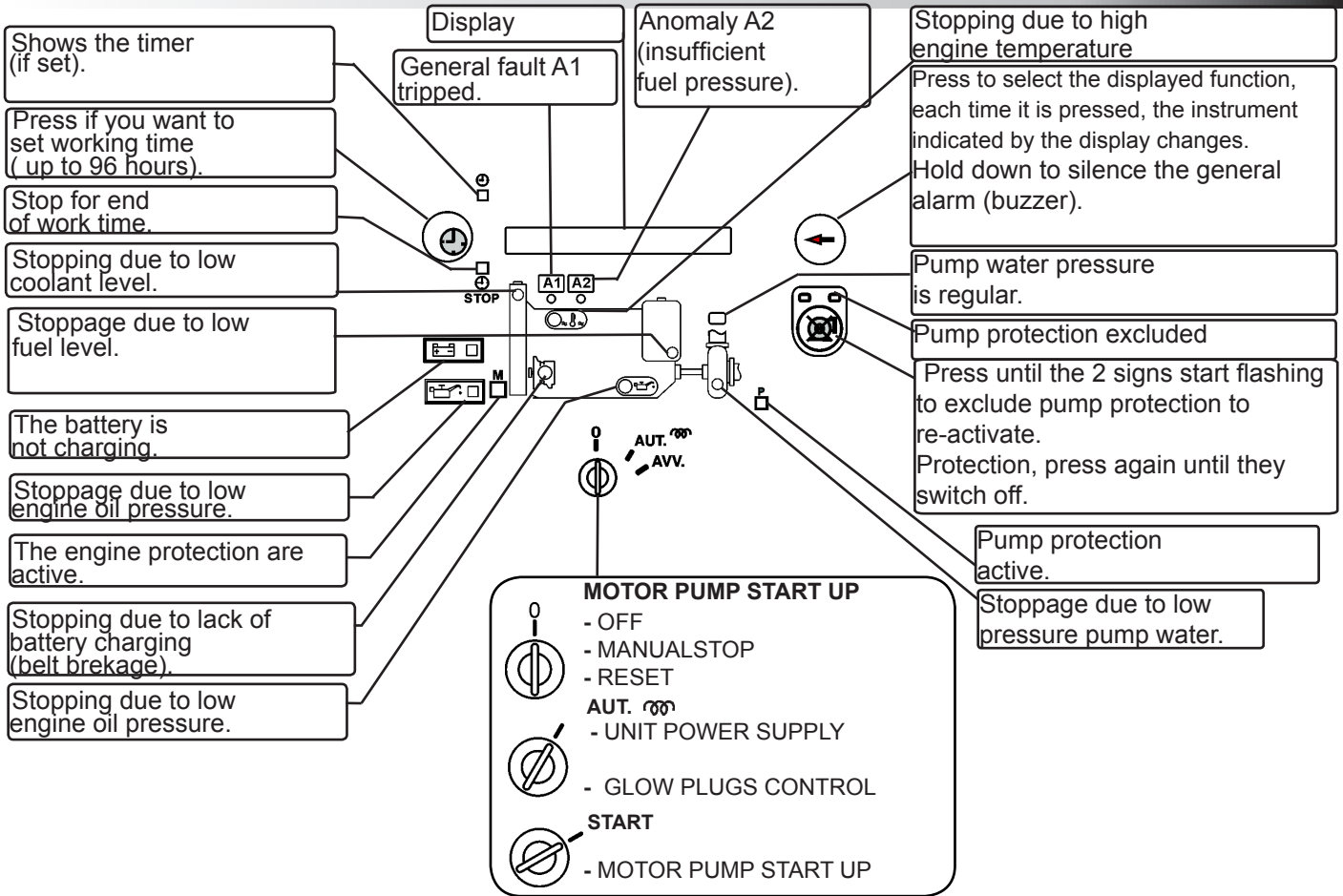

TECHNICAL DATA

Battery voltage supply	12 Vdc 24 Vdc
Voltage supply	8 ÷ 32V
Circuit loading with key at zero	0 mA
Maximum Consumption	265 mA a 12V 150 mA a 24V
Tachometer	Max 4000 RPM precision ± 10 RPM
Timer	1 ÷ 96h
Instruments precision: battery voltmeter, fuel level gauge	2%
Hour-meter	5 digits
Max load of the outputs: • starting motor (black) • stopping (yellow) • preheating (white/brown) • headlight (brown) • general alarm (red/green)	40A 3A 3A 3A 3A
Degree of protection: Box front Rear Connector	IP54 IP23 IP20
Installation conditions	for external use
Temperature range	-20 ÷ +60°C
Weight	950 g

OPERATION

START KEY



- OFF
- MANUAL STOP
- RESTORE PROTECTIONS, CANCEL PROTECTION EXCLUSION AND TIMER, DEACTIVATE INSTRUMENTS.



- CONTROL UNIT SUPPLY
- GLOW PLUGS CONTROL



- MOTOR PUMP START UP

OIL AND BATTERY INDICATOR LIGHTS



Lit up with key on "AUT", they switch off with the engine running





and regular oil pressure and battery charge system.

ENGINE PROTECTIONS



The engine protections are enabled when the ENGINE PROTECTIONS ACTIVE light  comes on, (20 seconds after the end of starting impulse and however 1 minute after positioning the key on "AUT").

Interventions of the protection probes (fitted on the engine), indicated by the relevant lights, stop the engine, they are memorised and can be split into two groups:



Immediate for:

- OIL PRESSURE SWITCH 
- OVERTEMPERATURE SWITCH 

Delayed by 5 seconds for:

- A1 ANOMALY PRESENT
- A2 (LOW FUEL PRESSURE)
- BATTERY CHARGING ALTERNATOR (BELT BREAKAGE) 
- FUEL LEVEL SWITCH 
 - flashing signal: 20% fuel reserve (T) (WITHOUT ENGINE STOP)
 - Signal always on: stop for minimum fuel level (W)
- PROBE FOR COOLANT LEVEL 

PUMP PROTECTION

The protections of the pump is enabled when the PUMP PROTECTIONS ACTIVE light  after the water pressure has remained stable for 2 consecutive minutes, indicated by the visual signal REGULAR PUMP PRESSURE  and in any case 10 minutes from starting of the engine).

Intervention of the protection (5 seconds by the lowering of WATER PRESSURE detected by the WATER PUMP PRESSURE SWITCH to be mounted on the pump) stops the engine, is stored and is indicated by the optical signalling INSUFFICIENT PRESSURE WATER pump. (SEE WATER PUMP PRESSURE ADJUSTMENT, page 5) . 

RESTORE: by turning the starter key onto "ZERO" (the engine pump will stop).



PUMP PROTECTION EXCLUSION (ENABLED ONLY WITH ENGINE RUNNING)

The push-button excludes pump protection:

- exclusion is obtained by keeping it pressed for at least 3 consecutive seconds; the function is indicated by the two intermittent lights .

- this exclusion is cancelled by pressing the push-button again or by turning the start key onto "ZERO".

OPERATION

STOPPING THE ENGINE PUMP

The control unit shut down the engine in three conditions:

- turning the starter key onto "ZERO".
- protection intervention.
- timer intervention at the end of the work period.

The unit adapts to two different stop system:

- by working the ELECTROMAGNET for 20 seconds which pulls the STOP lever.
- by cutting off power to the SOLENOIDVALVE shutting off the flow of fuel.

EMERGENCY STOP

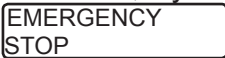
The emergency stop can be activated in all working conditions, by mounting one or more click-down push-button. On the display it's reported  .

GENERAL ALARM

This can be obtained by fitting on the outside an optical and/or acoustic signaller to be connected to its connector.

It is activated on protection intervention.

RESET: is obtained by turning the starter key back onto "ZERO".

INSTRUMENT

The control unit comprises four instruments which can be selected in sequence by pressing the button



HOUR-METER

-Total hours of operation (with the engine running the signal : pulsates to indicate the correct functioning of the HOUR-METER.

PRESSURE GAUGE

- Pressure water pump

TACHOMETER

- Speed of motor pump

FUEL LEVEL INDICATOR

- Fuel level percentage

VOLTMETER

- Battery voltage

} ON REQUEST

OPERATION TIMER

Always enabled, allows if necessary the motor pump to be operated for a settable time (maximum 96 hours), at the end of which it is stopped and on the display the end of work time indicator  comes on.

The work time is set by pressing the push-button  ( lights up) until the desired value appears on the

DISPLAY  .

On releasing the push-button, the timer automatically starts working, continuously displaying the remaining work time.

CANCELLING THE SET TIME

To zeroing the set time, to keep the push-button  pressed until it reaches zero.

GLOW PLUGS PREHEATING FACTORY-EXCLUDED

Is activated with key in AUT  the display shows the phrase

 .

The duration of the preheating action can be set.

Is indicated on the display when the action has ceased

 .

RADIATOR COOLANT LEVEL PROBE

FOR RADIATORS WITH PLASTIC EXPANSION TANK

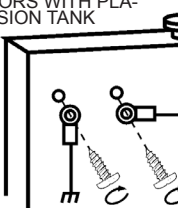

FOR RADIATORS WITH METAL EXPANSION TANK

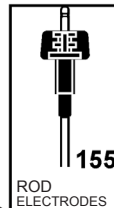
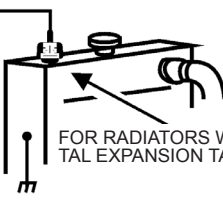

! If the function - LOW COOLING LIQUID LEVEL is not used: connect YELLOW/ ORANGE WIRE to earth .

WIRING DIAGRAM

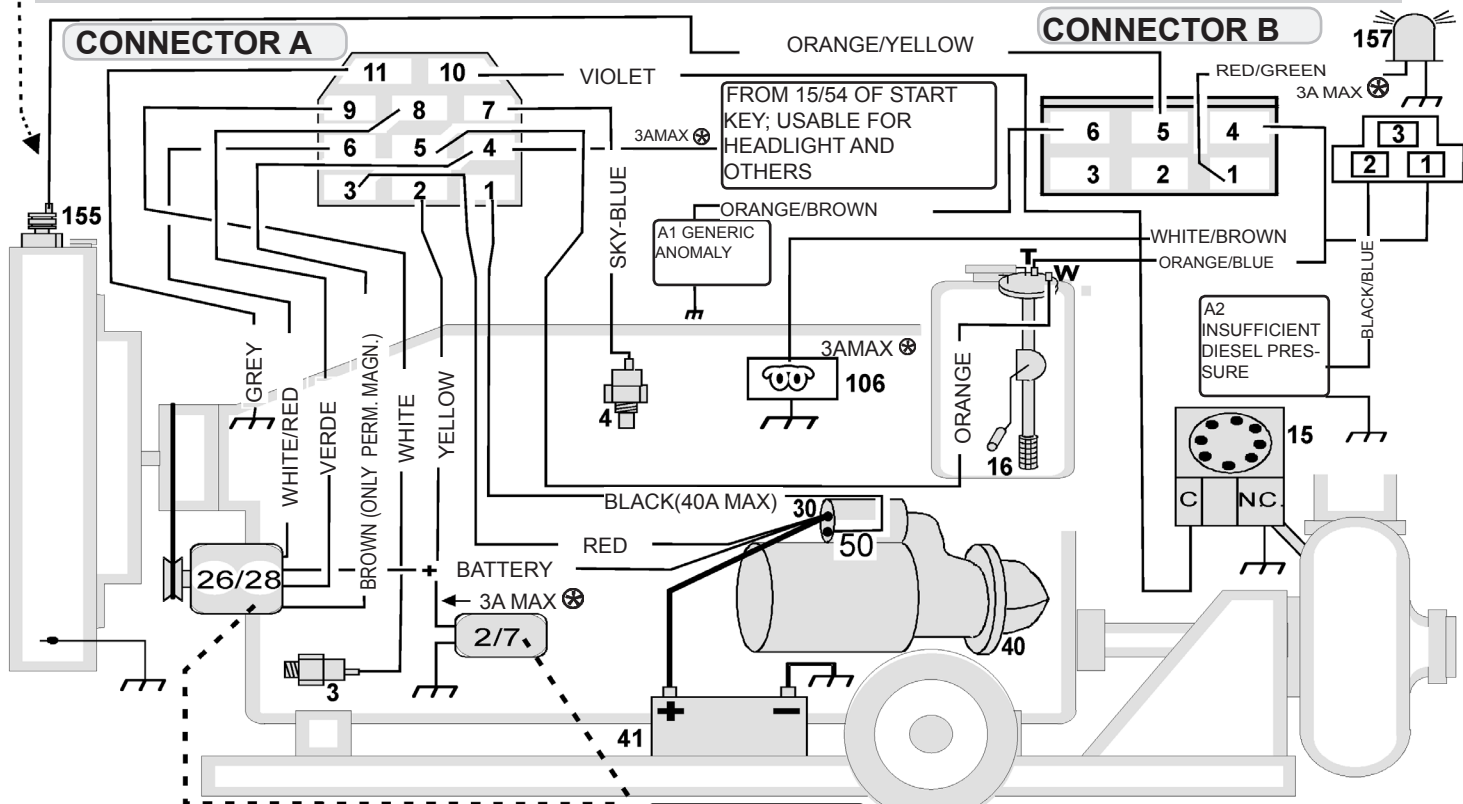

FUSES SUBSTITUTION
THE FUSES ARE INSIDE THE CONTROL UNIT. TO ACCESS THE INSIDE REMOVE THE FRONT PANEL BY UNSCREWING THE FOUR SCREWS. REPLACE WITH A FUSE OF THE SAME VALUE.

INSULATE POSSIBLE CABLES NOT CONNECTED

⊕ ATTENTION
FOR LOADS WITH HIGHER ABSORPTION 3A IT IS ESSENTIAL TO PUT A RELAY

ELIMINATE THE BRIDGE WHEN CONNECTING THE EMERGENCY BUTTON

EMERGENCY STOP
This can be obtained with a latching button. on releasing the emergency button, starting or motion of the engine is stopped. To reset, release the button, and place the start key onto ZERO.

CHARGE BATTERY ALTERNATOR:

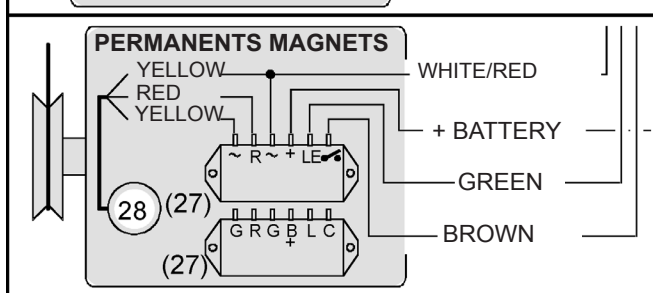
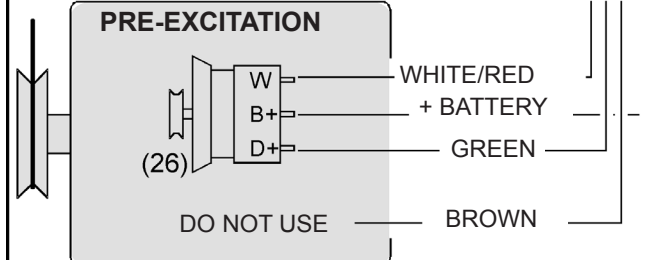

- ACCESSORIES ON REQUEST**
- (2/7) ELECTROMAGNET OR ELECTRO-VALVE ⊕
 - (4) THERMOSTATIC SWITCH
 - (15) WATER PUMP PRESSURE SWITCH
 - (16) FUELFLOAT
 - (155) RADIATOR LIQUID LEVEL PROBE

- MOUNTED ON ENGINE**
- (3) OIL PRESSURE SWITCH
 - (26/28) PERMANENT MAGNETS CHARGE ALTERNATOR OR PRE-EXCITATION CHARGE ALTERNATOR
 - (27) ALTERNATOR REGULATOR
 - (40) STARTING MOTOR
 - (41) BATTERY
 - (106) GLOW PLUGS
 - (157) GENERAL ALARM LIGHT ⊕

WATER PUMP PRESSURE SWITCH ADJUSTMENT
(To be fitted on the water pump)

Turn the knob to a value two bar less than the Pressure indicated on the pressure gauge. It is not necessary to adjust the pressure switch again if the working pressure remains constant.

EXCITED IN STOP MODE
ELECTROMAGNET: to activate the engine stop lever.
EXCITED IN DRIVE
SOLENOID : to close the fuel.

STOP SYSTEM ARRANGEMENT
The control unit has been designed to control stopping with an ELECTROMAGNET

To stop with SOLENOID VALVE cut and isolate the BLUE/BROWN lead.

USER PROGRAMMING AND TACHOMETER SETTING

ACCESS TO PROGRAMMING MODE.

Turn the key to 
DO NOT SET IN RUNNING
 Press (5") at the same time to DISPLAY

EXIT FROM PROGRAMMING MODE.

Re-position the key to zero



USER PROGRAMMING



USER PROGRAMMING





PRESS TO DISPLAY THE REQUIRED PROGRAMMING

LANGUAGE CHOICE

LANGUAGE CHOICE. The language set up in the factory is ITALIAN; the languages that can be selected are: ENGLISH - FRENCH - GERMAN - SPANISH and PORTUGUESE.

LANGUAGE CHOICE ITALIAN

 
 Press to select language

LANGUAGE SELECTION ENGLISH

Press and wait for PROGRAMMED to be written.

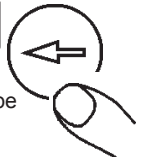

TACHOMETER SETTING

Start with the ignition key and bring the engine to idle at constant known speed for example via a portable tachometer.

Displayed on the display
 Example

700 RPM

1500 RPM

 
 Press until you get the right indication on the display

Press and wait for PROGRAMMED to be written.



NOTICES

Only for starting and surveillance of the diesel motor pump and stops it if there are anomalies in the parts controlled by probes.

It has been designed to be installed also on the machine.



Warning: adhere closely to the following advice

- Always follow the Wiring Diagram on page 5 when making connections.
- All technical interventions must be performed with the engine stationary and terminal 50 of the starter motor disconnected.
- Check that the line loading and the consumption of the connected equipment are compatible with the described technical characteristics described on page 2.
- Install in such a way that there is always adequate heat disposal.
- Always install under other equipment which produces or spreads heat.
- Never disconnect the battery terminals with the engine running.
- Never use a battery charger for the emergency start-up; the control unit could be damaged.
- In order to safeguard people and equipment, before connecting an external battery charger, disconnect the electrical system terminals from the battery poles.

THIS CONTROL UNIT IS NOT SUITABLE FOR OPERATING IN THE FOLLOWING CONDITIONS:

- Where the environmental temperature is outside the limits indicated in the Technical Data.
- Where the air pressure and temperature variations are so rapid as to produce exceptional condensation.
- Where there are high levels of pollution caused by dust, smoke, vapour, salts and corrosive or radioactive particles.
- Where there are high levels of heat from radiation caused by the sun, ovens or the like.
- Where attacks from mould or small animals are possible.
- Where there is the risk of fire or explosions.
- Where the control unit can receive strong vibrations or knocks.

ELECTROMAGNETIC COMPATIBILITY

This control unit functions correctly only if inserted in plants which conform with the CE marking standards; it meets the exemption requirements of the standard EN61326-1 but it cannot be excluded that malfunctions could occur in extreme cases due to particular situations.

The installer has the task of checking that the disturbance levels are within the requirements of the standards.

CONDUCTION AND MAINTENANCE

The following maintenance operations should be performed every week:

- check that the indicators function;
- check the batteries;
- check that the conductors are tight, check the condition of the terminals.

UNLESS WE MAKE A WRITTEN DECLARATION STATING THE CONTRARY, THIS CONTROL UNIT IS NOT SUITABLE FOR USE AS A CRITICAL COMPONENT IN EQUIPMENT OR PLANTS RESPONSIBLE FOR KEEPING PERSONS OR OTHER LIVING BEINGS ALIVE.

YOUR ELECTRICAL TECHNICIAN CAN ASK US ANYTHING ABOUT THIS CONTROL UNIT BY TELEPHONING ONE OF OUR TECHNICIANS

ORDERING DATA

Type CEM-370 cod. 00210722

ACCESSORIES KIT

Pre-wired female
connector cod. 70804416
kit rods CEP-CEM cod. 40804362

ACCESSORIES ON REQUEST

PUMP WATER PRESSURE SWITCH AND GAUGE

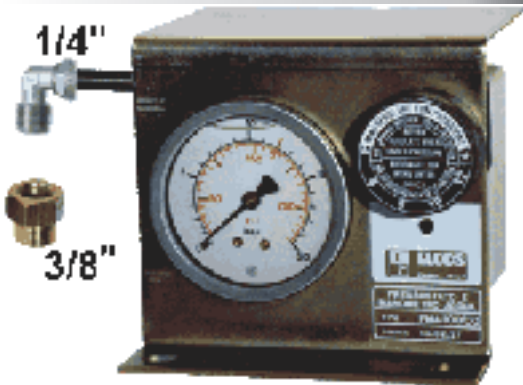

PMA-100/00 (4-14 bar) cod. 00500227
PMA-102/00 (2-5 bar) cod. 00500235

PUMP WATER PRESSURE SWITCH



PA-100/00 (4-14 bar) code 00500226
PA-102/00 (2-5 bar) code 00500231

RADIATOR COOLANT LEVEL PROBE ROD ELECTRODE

(complete with: rivet fitting, bolt, nut, washer, seal and female connector)



type AST-015/00 code 40241012

SCREW ELECTRODE

(complete with terminals)

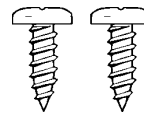

type E-25 code 40190115

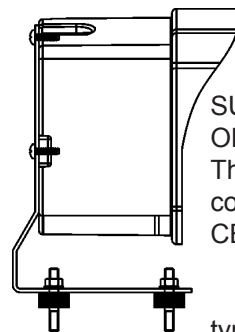

SUPPORT FOR INSTALLATION
ON BASE

The support facilitates replacement of
control units of type CEM-330 and
CEM-350

type CRU-004 cod. 40493382